

# CITY THEATRICAL

NEW YORK • LONDON

An Environmental Lights Company

## 1500 Follow Spot Yoke for Source Four

Rev 1.4

© 2024 City Theatrical, LLC.

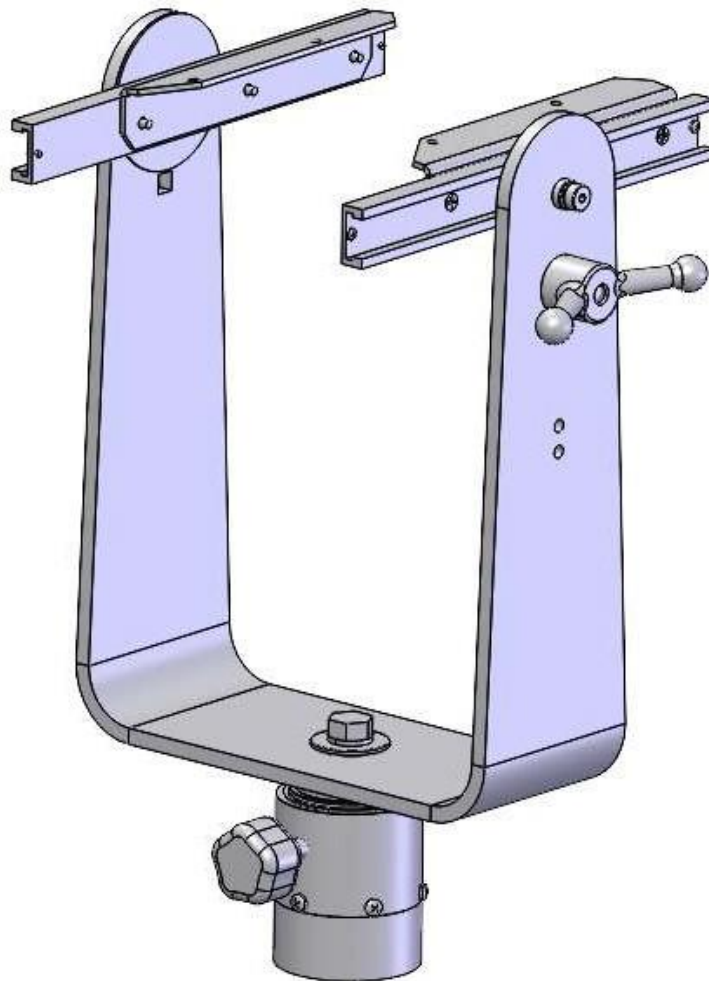

475 BARELL AVENUE, CARLSTADT, NJ 07072  
800/230/9497 201/549/1160 201/549/1161 FAX  
www.citytheatrical.com

## City Theatrical Follow Spot Yoke

### Getting Started with the City Theatrical Follow Spot Yoke

Congratulations on the purchase of your City Theatrical Follow Spot Yoke. The City Theatrical Follow Spot Yoke is a professional quality device that can provide smooth pan and tilt operation to your lighting fixture. A heavy steel yoke gives mass and prevents vibration, and ball bearings on the pan and tilt create extremely smooth movement, even on very long throws.

The City Theatrical Follow Spot Yoke can be configured for use with the Source Four™ 19°, 50°, 10°, and 5°. A track allows the lighting fixture and any accessories to be balanced for ease of operation.

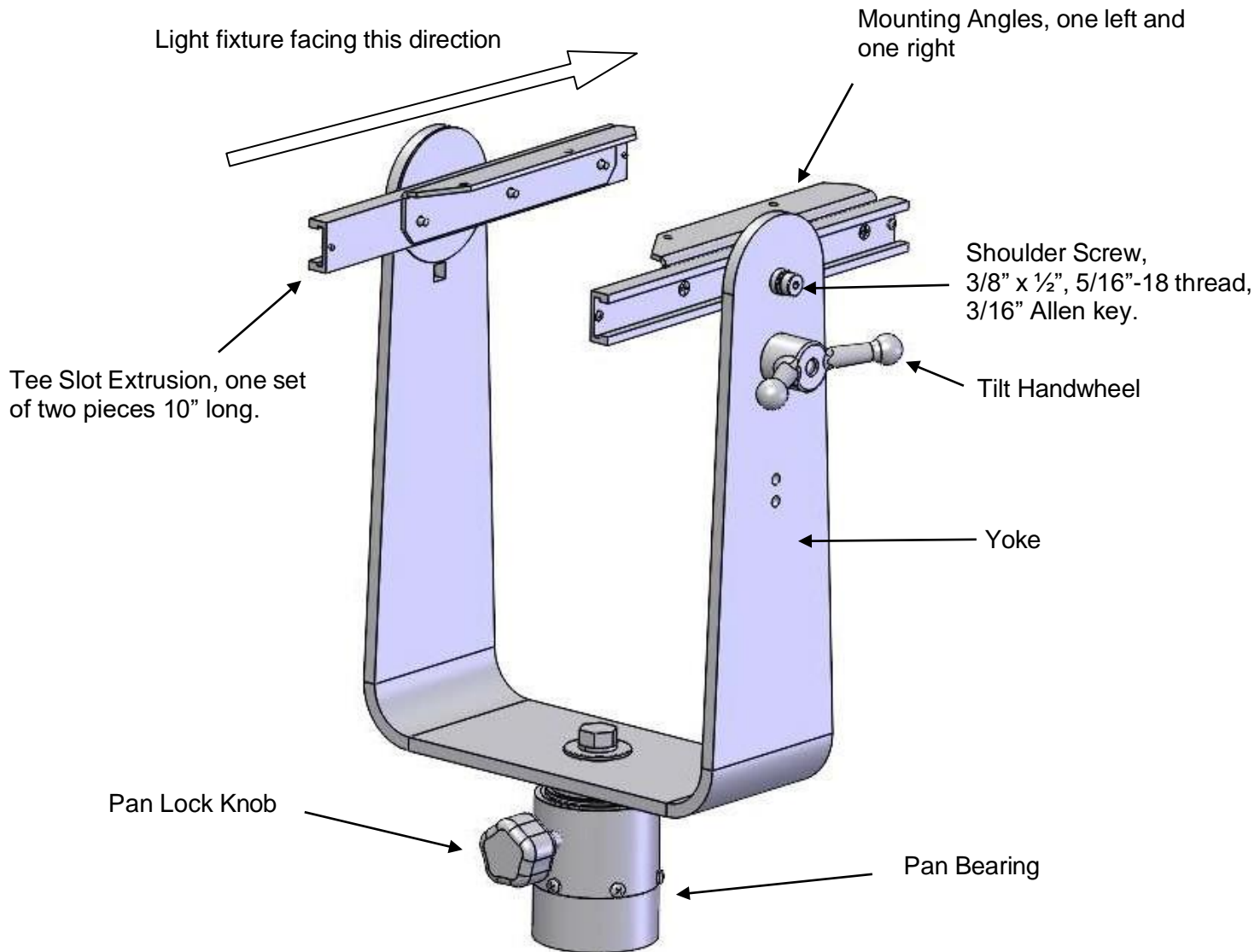

SHOWN FOR RIGHT HAND OPERATION of 10°-50°

## City Theatrical Follow Spot Yoke

### Mounting your Follow Spot Yoke

The City Theatrical Follow Spot can be mounted in a variety of ways. The bottom of the pan bearing has female 1 1/2" NPT pipe threads, and any length of 1 1/2" pipe can be threaded into it. Using a 36" piece of 1 1/2" pipe threaded into a 50 lb. boom base is a typical method.

The Follow Spot Yoke can be mounted in a variety of positions, such as:

- On a stand of 1 1/2" pipe with a boom base
- Underhung from a pipe
- Overhung on a hand rail

These diagrams illustrate three possible hanging methods:



Pipe and base mount

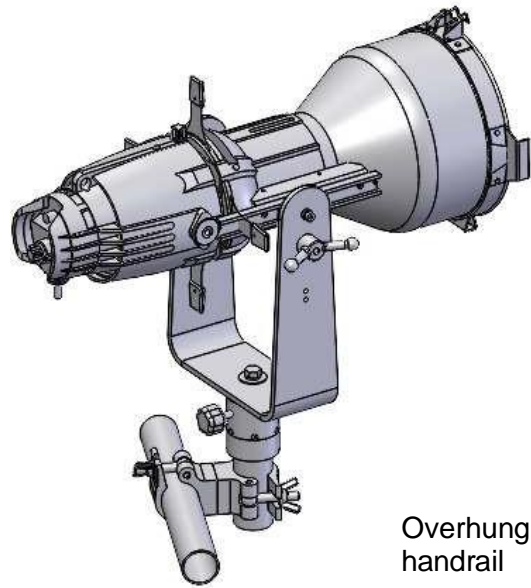

Overhung on handrail

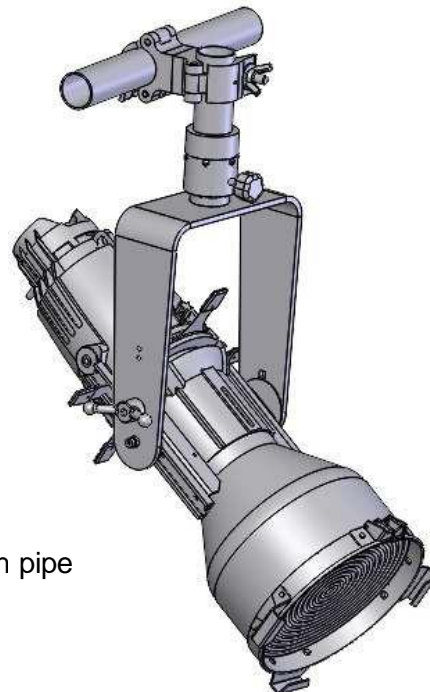

Underhung on pipe

## City Theatrical Follow Spot Yoke

### Preparing Your Lighting Fixture

If you are planning to use a 19°-50° or a 10° Source Four, you will need to remove the shutters from the lighting fixture. This is not necessary, but may be desirable for a 5° Source Four to prevent the shutter blades from accidentally being moved during operation. Remove the shutters by removing the four machine screws which hold the two halves of the Source Four barrel together and exposing the shutter, pressure plate, and shutter spring parts. Remove the shutter blades, but reinstall the pressure plates and springs. Do not reinstall the existing four machine screws into the barrel. Go on the next step:

Two Angle Brackets allow your Source Four to be installed in the Follow Spot Yoke. Replace the four ETC machine screws with the enclosed #8-32 x 1 1/2" pan head Philips machine screws into the Source Four's existing #8-32 hex nuts.

Next, install the two Tee Slot Extrusions using the enclosed #8-32 x 3/8" flat head Philips machine screws (three screws per extrusion). For 19°-50° or 10° Source Four, install the Tee Slot Extrusions with the excess track overhanging toward the rear of the lighting fixture. For the 5° Source Four, the Tee Slot Extrusions overhang the Angle Brackets toward the front of the lighting fixture. See diagrams below.

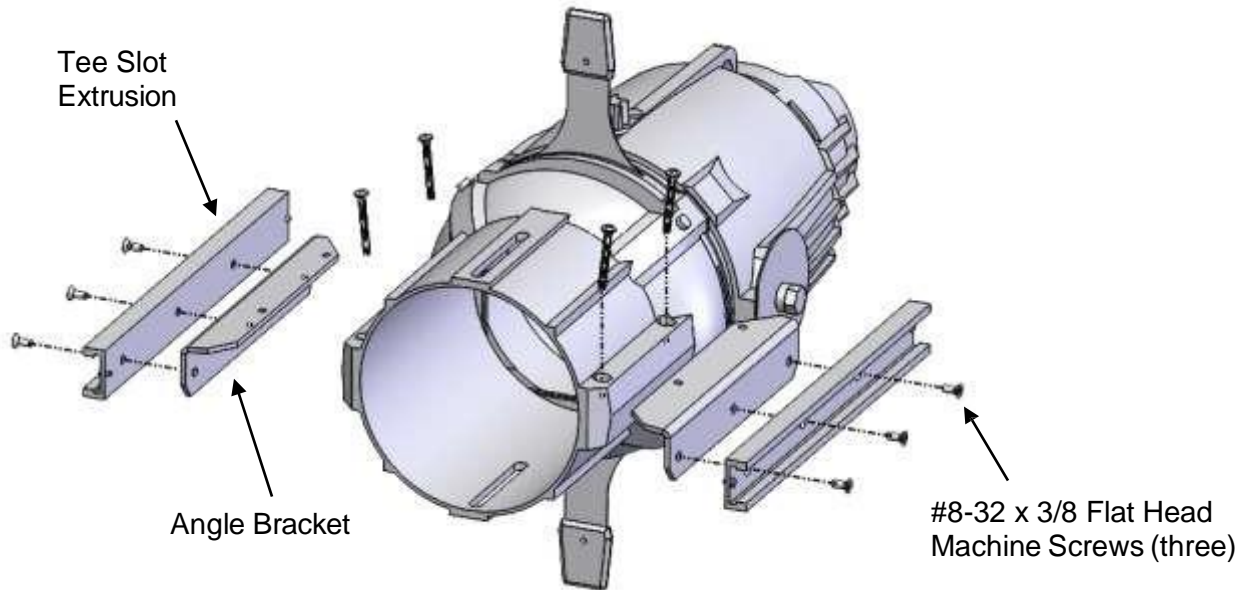

SHOWN FOR RIGHT HAND OPERATION of 10°-50°

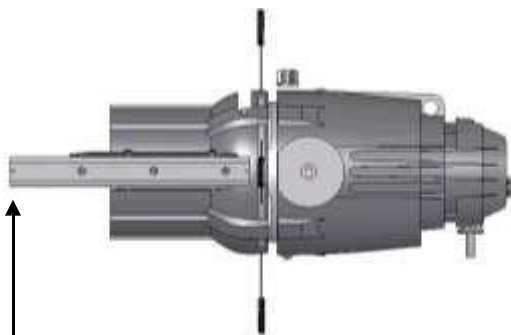

**For 5° Source Four**  
Tee Slot Extrusions overhang toward front of lighting fixture. Shutters may or may not be removed.

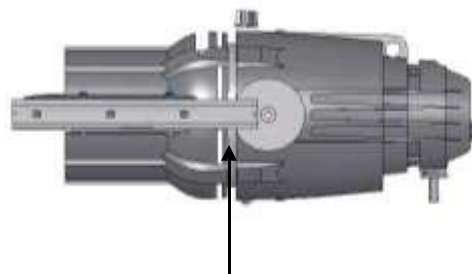

**For 19°-50° or 10° Source Four**  
Tee Slot Extrusions overhang toward rear of lighting fixture. Shutters must be removed.

## City Theatrical Follow Spot Yoke

### Installing the Source Four into the Follow Spot Yoke

Note the two Tee Blocks that slide into the Tee Slot Extrusion. Using a 3/16" Allen key, slightly loosen the two 3/8" x 1/2" socket head shoulder screws to free the Tee Blocks. Carefully insert the Tee Slot Extrusions onto the Tee Blocks. Tighten the tilt handwheel. Temporarily tighten the shoulder screws. Install four 4-40 x 3/16" pan head machine screws, one in each end of each Tee Slot Extrusion. These screws serve as safety devices to prevent the Tee Blocks from accidentally slipping out of the Tee Slot Extrusion track.

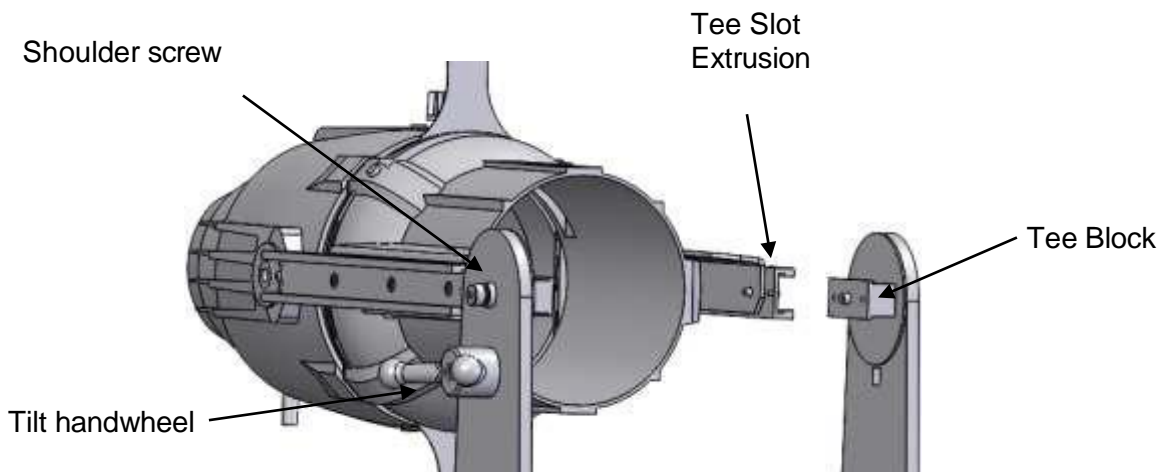

### Install the Lens Tube into the Source Four

Install the Lens Tube into the Source Four and install the two #10-32 screws (one plastic thumbscrew and one Philips machine screw) that hold the Lens Tube to the lighting fixture. Plug in the lighting fixture into a switch or dimmer and dress the cable to insure that it does not restrict the yoke's movement or its balance. Turn on the lighting fixture and adjust the sharpness of the beam to the degree that you think is appropriate.

### Balance the Lighting Fixture in the Yoke

The lighting fixture can be adjusted forward or backward in the Tee Slot Extrusion to establish a perfect balance point. To test the balance, carefully loosen the tilt locking knob and feel if the fixture is front heavy or back heavy. To adjust the balance, loosen the two shoulder screws and evenly push the fixture forward or backward in the Tee Slot Extrusion until it balances exactly. Lock the shoulder screws again. Test and repeat if necessary.

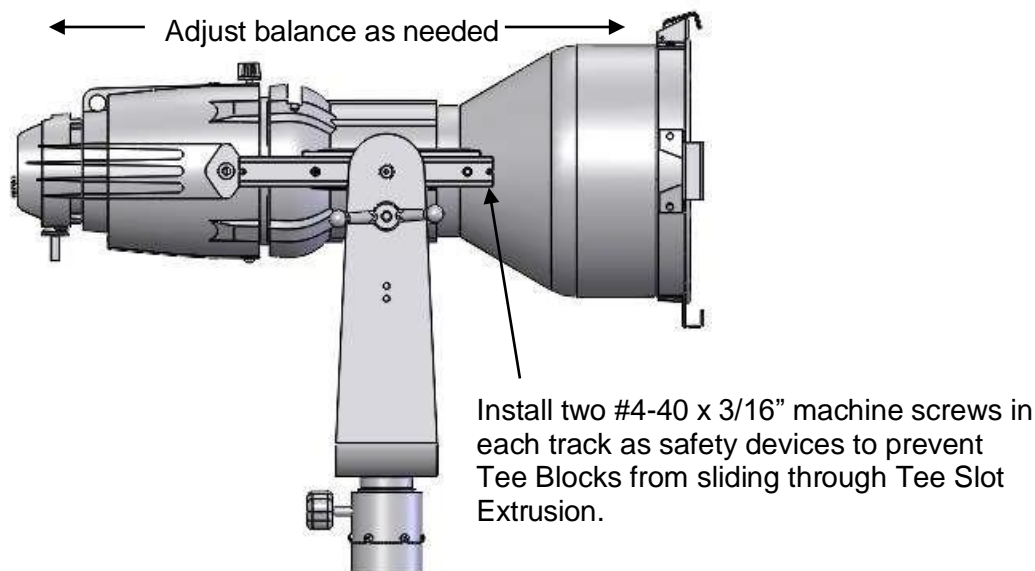

City Theatrical Follow Spot Yoke

**Using Other City Theatrical Accessories with Your Follow Spot Yoke**

City Theatrical has created a range of accessories to make your Follow Spot more versatile and easier to operate.

Part Number	Name	Use
2180	Drop-In Iris	Change size of beam
1520	Follow Spot Yoke Handle	Provides handgrips at front and/or rear of Follow Spot.
1360	Follow Spot Handle	Clamps onto rear of Source Four to provide a handgrip.
1519	Follow Spot Handle, Source Four Series 3 LED	Provides handgrips at the rear of Source Four Series 3 LED.
1522	Follow Spot Handle for Source Four LED	Clamps onto the rear of ETC Source Four Series 1 or Series 2 LED Ellipsoidal to provide a handgrip.
1410	Drop-In Boomerang for 19°-50° Source Four	Manually changes six frames of color

		
2180	1520	1360
		
1519	1522	1410