

# **CITY**

---

# **THEATRICAL**

---

**NEW YORK • LONDON**

An **Environmental Lights** Company

## **1502 Follow Spot Yoke, Source Four LED**

Rev 1.2

© 2024 City Theatrical, LLC

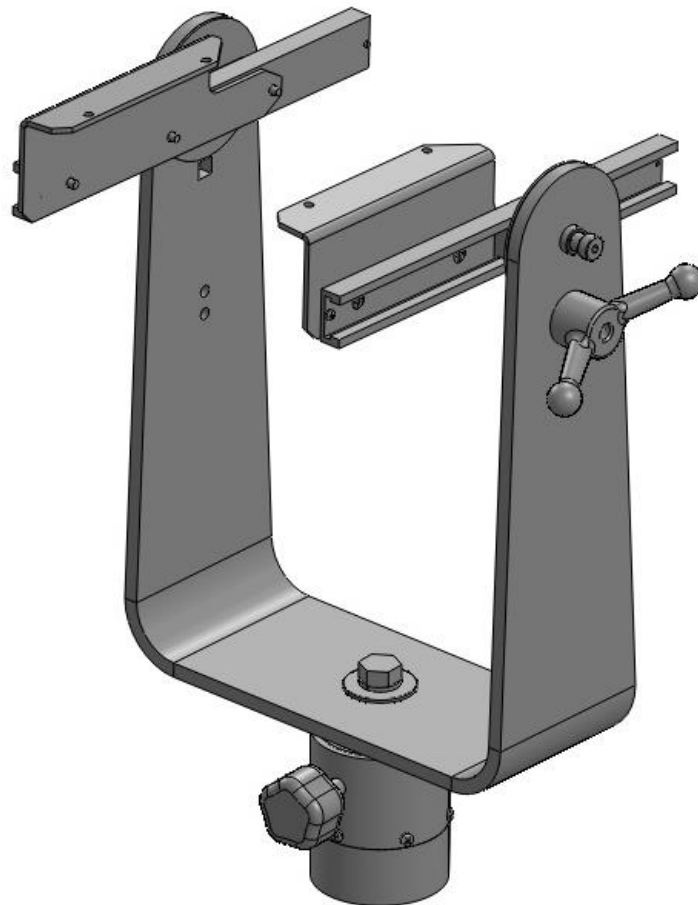

**475 BARELL AVENUE, CARLSTADT, NJ 07072**  
**800/230/9497 201/549/1160 201/549/1161 FAX**  
**[www.citytheatrical.com](http://www.citytheatrical.com)**

## City Theatrical Follow Spot Yoke

### Getting Started with the City Theatrical Follow Spot Yoke for Source Four LED

Congratulations on the purchase of your City Theatrical Follow Spot Yoke for Source Four LED. The City Theatrical Follow Spot Yoke is a professional quality device that can provide smooth pan and tilt operation to your Source Four LED. A heavy steel yoke gives mass and prevents vibration, and ball bearings on the pan and tilt create extremely smooth movement, even on very long throws.

The 1502 City Theatrical Follow Spot Yoke can be configured for use with the:

- Source Four LED
- Source Four Series 1
- Source Four Series 2 LED
- ETC ColorSource Spot
- ETC ColorSource Spot V

All lenses from 5° to 50° can be used. A track allows the lighting fixture and any accessories to be perfectly balanced for ease of operation.

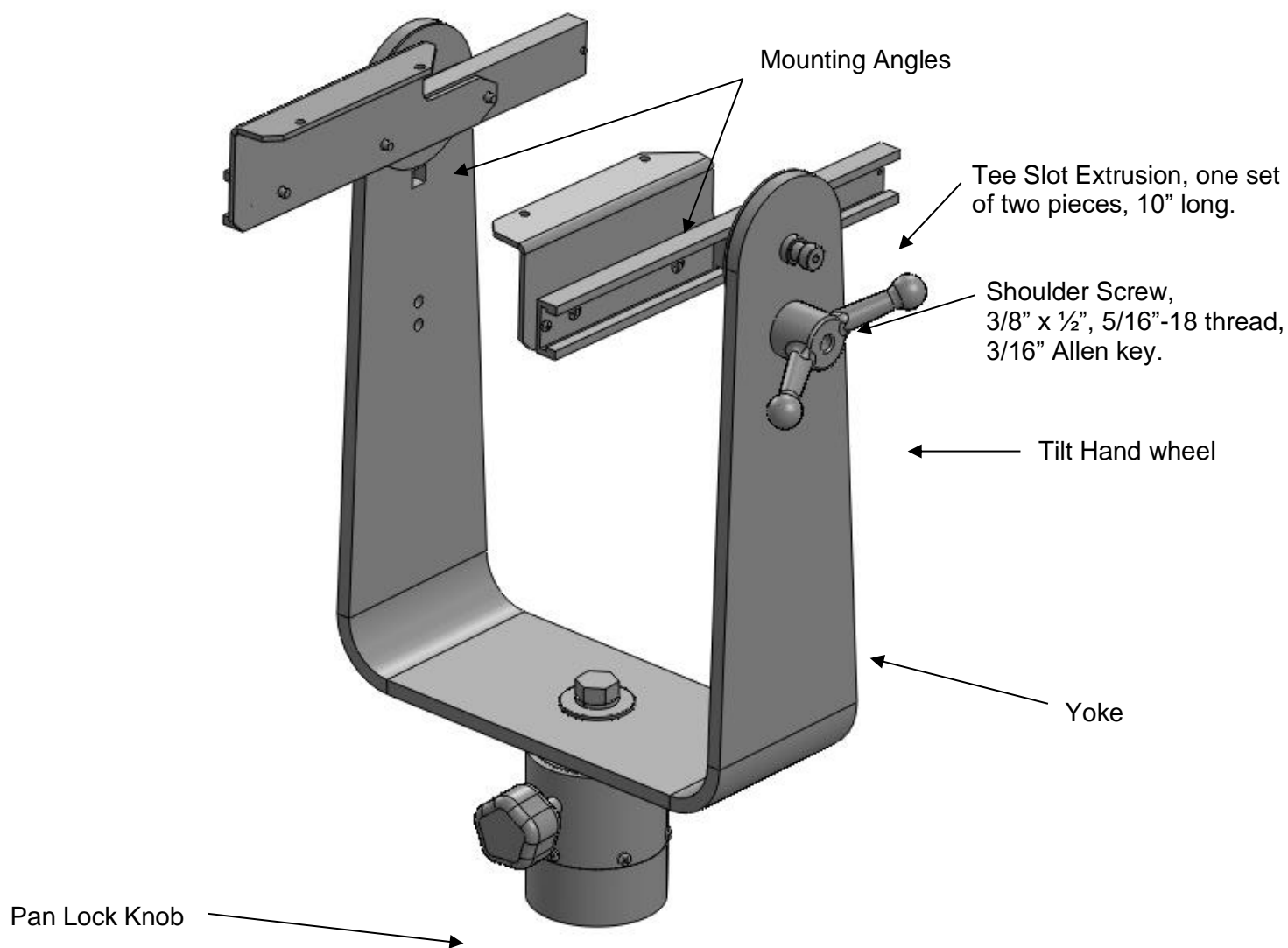

## City Theatrical Follow Spot Yoke



### Mounting your Follow Spot Yoke Source Four LED

The City Theatrical Follow Spot for Source Four LED can be mounted in a variety of ways. The bottom of the pan bearing has female 1 1/2" NPT pipe threads, and any length of 1 1/2" pipe can be threaded into it. Using a 36" piece of 1 1/2" pipe threaded into a 50 lb. boom base is a typical method.

The Follow Spot Yoke can be mounted in a variety of positions, such as:

- On a stand of 1 1/2" pipe with a boom base
- Underhung from a pipe
- Overhung on a handrail

These diagrams illustrate three possible hanging methods:



Pipe and base mount

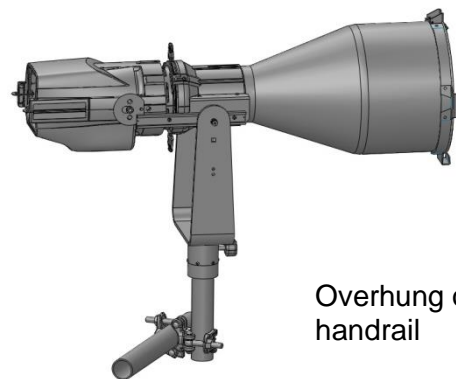

Overhung on handrail

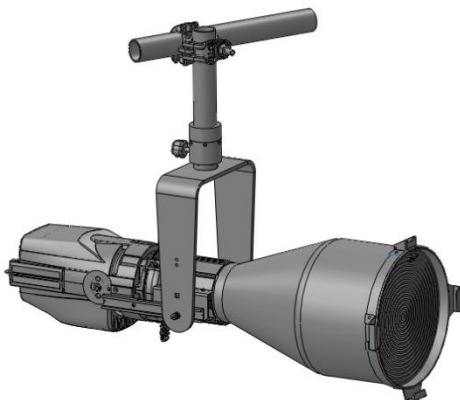

Underhung on pipe

## City Theatrical Follow Spot Yoke

### Preparing Your Lighting Fixture

If you are planning to use a 14°-50° or a 10° Source Four, you will need to remove the shutters from the lighting fixture. This is not necessary, but may be desirable for a 5° Source Four to prevent the shutter blades from accidentally being moved during operation. Remove the shutters by removing the four machine screws which hold the two halves of the Source Four barrel together and exposing the shutter, pressure plate, and shutter spring parts. Remove the shutter blades, but reinstall the pressure plates and springs. Do not reinstall the existing four machine screws into the barrel. Go on the next step:

Two Angle Brackets allow your Source Four to be installed in the Follow Spot Yoke Source Four LED. Replace the four ETC machine screws with the enclosed #8-32 x 1 1/2" pan head Philips machine screws into the Source Four's existing #8-32 hex nuts.

Next, install the two Tee Slot Extrusions using the enclosed #8-32 x 3/8" flat head Philips machine screws (three screws per extrusion) as shown in the illustration below.

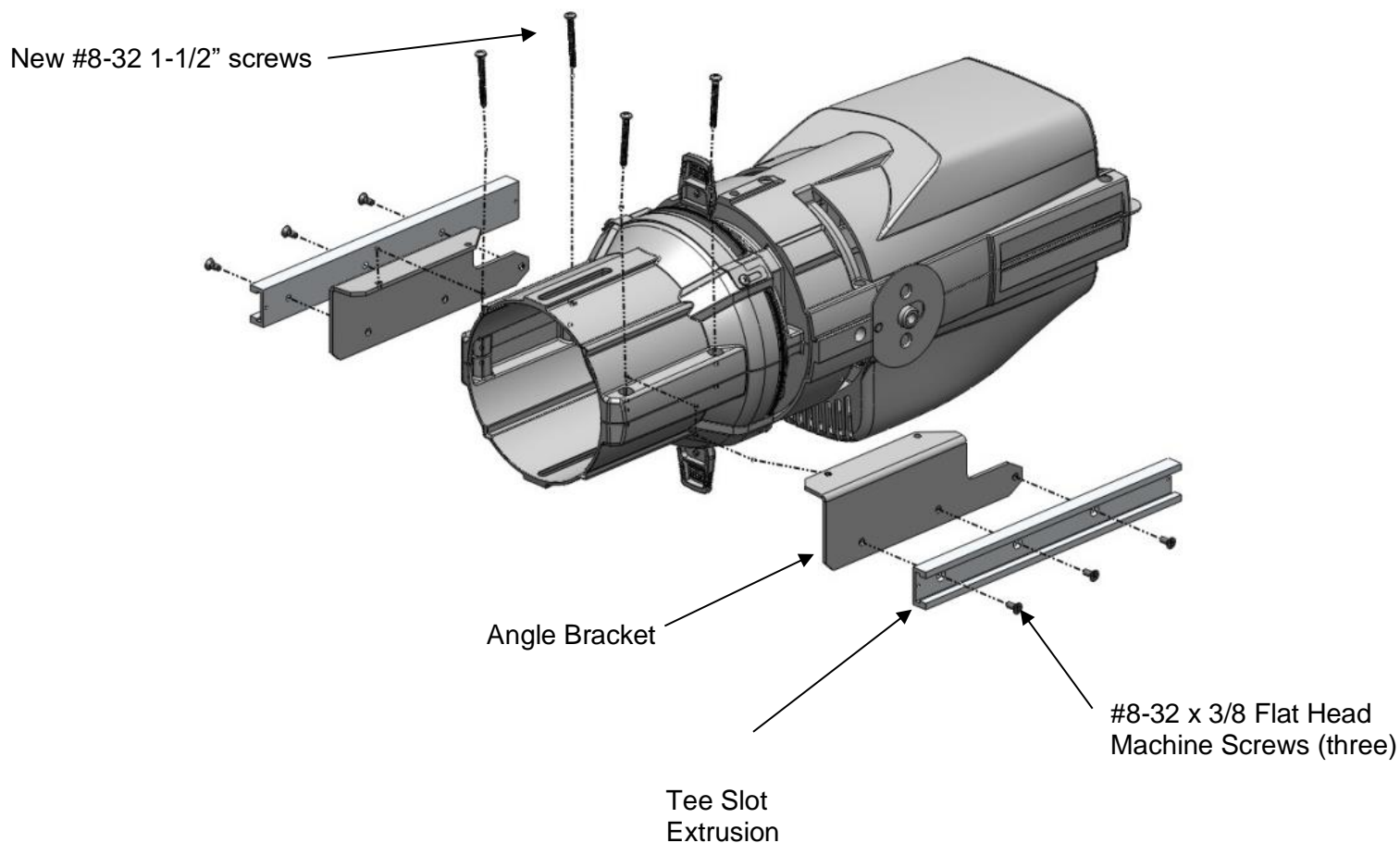

## City Theatrical Follow Spot Yoke

**Note:** If you experience difficulty installing new #8-32 x 1 1/2" screws it may be due to incompletely threaded holes on the Source Four barrel. Threads can be formed completely with the following steps:

1. Remove the bottom half of the barrel, locate the threaded holes in the barrel.
2. With the top half of the barrel removed Screw the original ETC machine screws into the hole completely then remove. This will form the remaining threads.
3. Reassemble barrel and insert longer 1-1/2" machine screws into completely formed threaded holes.

### Installing the Source Four into the Follow Spot Yoke

Note the two Tee Blocks that slide into the Tee Slot Extrusion. Using a 3/16" Allen key, slightly loosen the two 3/8" x 1/2" socket head shoulder screws to free the Tee Blocks. Carefully insert the Tee Slot Extrusions onto the Tee Blocks. Tighten the tilt handwheel. Temporarily tighten the shoulder screws

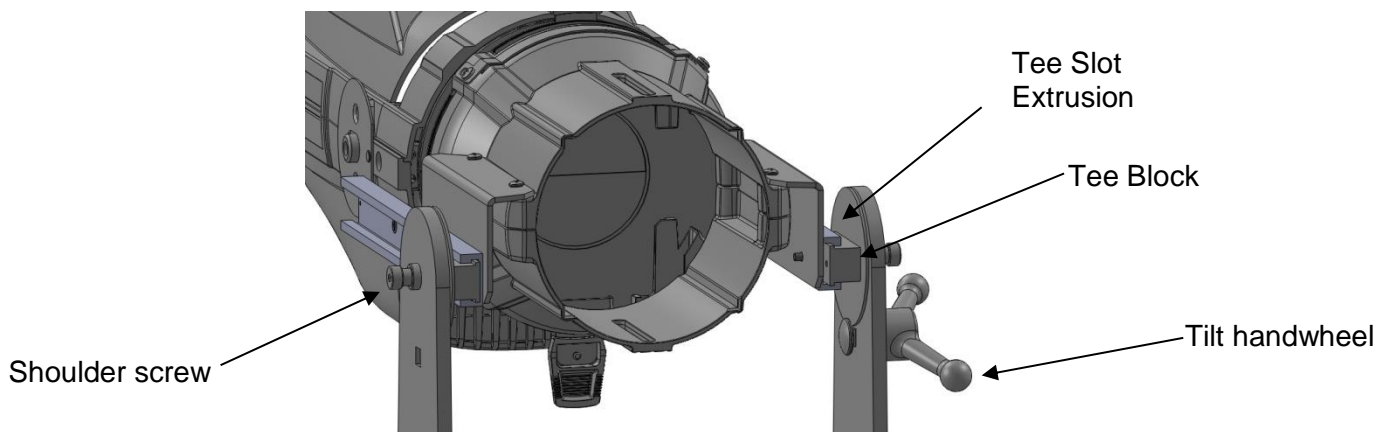

Install four #4-40 x 3/16" pan head machine screws, one in each end of each Tee Slot Extrusion. These screws serve as safety devices to prevent the Tee Blocks from accidentally slipping out of the Tee Slot Extrusion track.

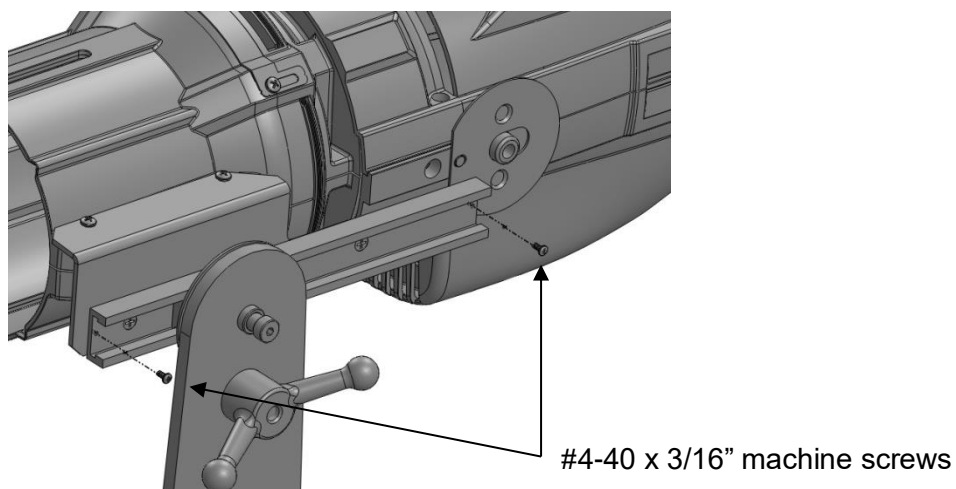

## City Theatrical Follow Spot Yoke

### **Install the Lens Tube into the Source Four**

Install the Lens Tube into the Source Four and install the two #10-32 screws (one plastic thumbscrew and one Philips machine screw) that hold the Lens Tube to the lighting fixture. Plug in the lighting fixture into a switch or dimmer and dress the cable to insure that it does not restrict the yoke's movement or its balance. Turn on the lighting fixture and adjust the sharpness of the beam to the degree that you think is appropriate.

### **Balance the Lighting Fixture in the Yoke**

The lighting fixture can be adjusted forward or backward in the Tee Slot Extrusion to establish a perfect balance point. To test the balance, carefully loosen the tilt locking knob and feel if the fixture is front heavy or back heavy. To adjust the balance, loosen the two shoulder screws and evenly push the fixture forward or backward in the Tee Slot Extrusion until it balances exactly. Lock the shoulder screws again. Test and repeat if necessary.

← Adjust balance as needed →

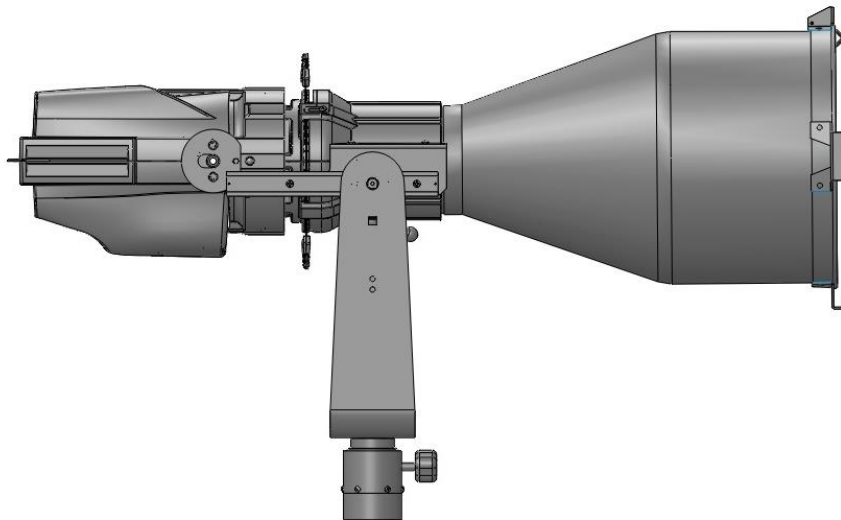





## City Theatrical Follow Spot Yoke

### Using Other City Theatrical Accessories with Your Follow Spot Yoke

City Theatrical has created a range of accessories to make your Follow Spot more versatile and easier to operate.

Part Number	Name	Use
2180	Drop-In Iris	Change size of beam
1520	Follow Spot Yoke Handle	Provides handgrips at front of Follow Spot.
1360	Follow Spot Handle	Clamps onto rear of Color Source to provide a handgrip.
1522	Follow Spot Handle for ETC Series 1 or 2 LED Ellipsoidal	Insert into rear of Source Four LED Series 1 or 2 to provide a handgrip.

		
2180	1520	1360
		
1522		